



BROIL-O-DOGS

Model 174CBA, 174SBA, 175CBA & 175SBA

Features/Benefits:

- ★ Star's Broil-O-Dogs are designed for ease of use and perfect broiling of your products with easily accessible bun storage.
- ★ Stainless steel cradle-type hot dog wheel provides basting action that rolls the dogs resulting in more evenly cooked products with uniform color.
- ★ Stainless steel spike-type hot dog wheel-spears product and rotates while cooking.
- ★ Special glass reflects radiant energy back into the cabinet, increasing speed of cooking and decreasing exterior temperature.
- ★ Built-in pull out heated bun warmer with removable, washable, stainless steel pan keeps buns warm and ready to serve without becoming soggy.
- ★ Momentary wheel switch for easy loading and unloading of product.
- ★ Adjustable thermostat provides a wide range of temperature control.
- ★ Colorful merchandising graphics build impulse sales.
- ★ Illuminated cabinets for better visibility.
- ★ Lighted "on-off" switch for visual control.
- ★ Optional accessory items include sneeze guard and self-serve door.



Model 174CBA



Model 175CBA

Applications:

With four model variations of cradle or spike-type wheels to choose from, Star offers you the right broiler for use in convenience stores, quick serve restaurants, concession areas or wherever you want to increase your hot dog sales.

Construction:

Stainless steel construction with cradle or spike wheel options with built in 50 watt bun warmer with 6 x 10 x 4 or 12 x 10 x 4 pan with rack for buns. Unit features a lighted on/off switch, adjustable infinite control and a momentary wheel switch. Shipped with a 6' lead-in cord and NEMA 5-15 plug and CEE7-7 for 230V.

Warranty:

Broil-O-Dogs are covered by Star's one year parts and labor warranty.





BROIL-O-DOGS

Model 174CBA, 174SBA, 175CBA & 175SBA

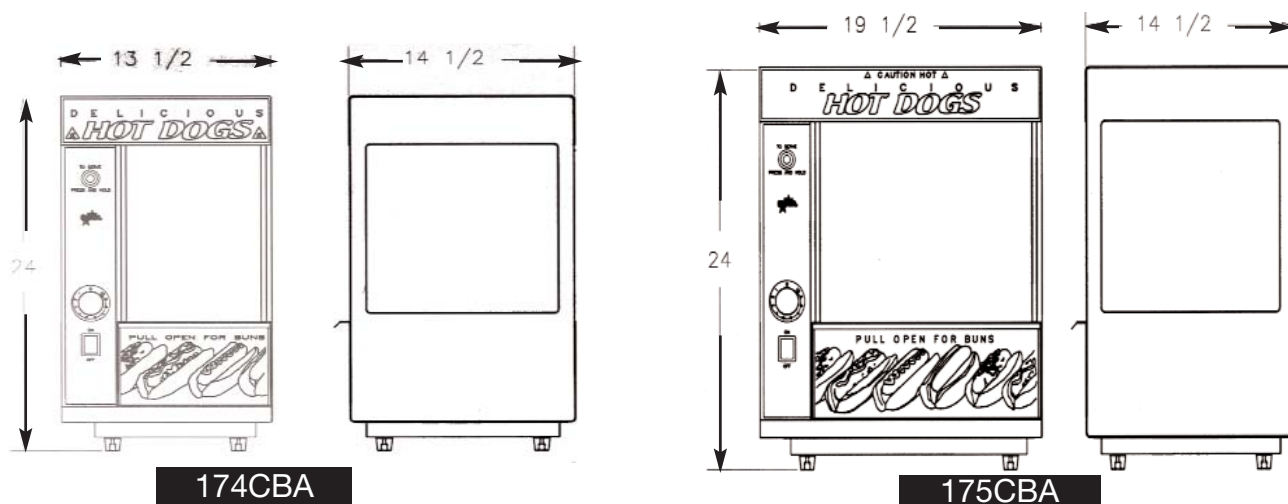

174CBA

175CBA

Specifications

Model #	Capacity		Dimensions			Approximate Weight	
	Dogs	Buns	Height Inches (cm)	Width Inches (cm)	Depth Inches (cm)	Installed lbs. (kg)	Shipping lbs. (kg)
174CBA, cradle wheel	18	12	24 (61)	13-1/2 (34.3)	14-1/2 (36.8)	44 (19.9)	54 (24.3)
174SBA, spike wheel	24	12	24 (61)	13-1/2 (34.3)	14-1/2 (36.8)	41 (18.6)	56 (25.2)
175CBA, cradle wheel	36	32	24 (61)	19-1/2 (49.5)	14-1/2 (36.8)	56 (25.4)	71 (31.9)
175SBA, spike wheel	48	32	24 (61)	19-1/2 (49.5)	14-1/2 (36.8)	52 (23.6)	66 (29.7)

Accessories

Model #	Description	Shipping Weight
174SGA	Sneeze Guard for Model 174CBA, 174SBA	.1 lb. (0.5 kg)
174SSDA	Self-Serve Door for Model 174CBA, 174SBA	.3 lbs. (1.4 kg)
175SGA	Sneeze Guard for Model 175CBA, 175SBA	.2 lbs. (0.9 kg)
175SSDA	Self-Serve Door for Model 175CBA, 175SBA	.4 lbs. (1.8 kg)

Electrical Data

Model #	Volts	Watts	Amps	NEMA Plug	
				120V	230V
174CBA	120 (or) 230V	1150	9.58/4.79	5-15	CEE7-7
174SBA	120 (or) 230V	1150	9.58/4.79	5-15	CEE7-7
175CBA	120 (or) 230V	1350	11.25/5.63	5-15	CEE7-7
175SBA	120 (or) 230V	1350	11.25/5.63	5-15	CEE7-7

Typical Specifications

Hot dog broiler is constructed of stainless steel and is available with cradle or spike wheel with a built in bun warmer and optional sneeze guard. Unit features a lighted on-off switch, momentary wheel switch, adjustable infinite control and colorful merchandising sign. Broiler operates on 120V or 230V and is approved by Underwriters Laboratories, UL listed to NSF Standard 4 and Canadian standards. Units are shipped with a 6' lead-in cord and NEMA 5-15/CEE7-7. The 174 CBA/SBA has a 1050 watt heating element. The 175 CBA/SBA has a 1250 watt heating element. Printed in the U.S.A.