



CLASSIC STEAMRO, JR. HOT DOG STEAMER

Model 35SSC

Features/Benefits:

- ★ Features top loading design for easy access to your hot dogs, buns and more!
- ★ Lid design opens to the side for easy and safe operation.
- ★ Side by side design provides more control of heat and humidity to satisfy all your steaming needs.
- ★ Bun compartment features a humidity control system and a bun rack to keep buns warm and fresh.
- ★ Powerful immersion element for fast heat up and consistent temperature and humidity control.
- ★ Adjustable thermostat ensures quick start up and fast recovery for peak operating times.
- ★ Large capacity six quart water pan for all day steaming.
- ★ Full view tempered glass on both the operator's and customer's side for excellent merchandising.
- ★ Front drain valve for easy cleaning.
- ★ Hot dog juice tray keeps your water pan clean. (optional accessory)
- ★ Attractive scratch resistant graphics, on both operator and customer sides, build impulse sales.



**Model 35SSC
Customer Side**

Applications:

Designed for fast food and other snack bars, stadiums, ball parks, arenas, convention centers, fast food chains or other high volume foodservice operations; Star's Classic Steamro, Jr. hot dog and bun steamer is the #1 choice for a variety of foodservice operations worldwide.

Quality Construction:

Constructed of stainless steel with two lift off lids. Equipped with powerful immersion type element. Shipped with a six foot lead-in cord and NEMA 5-15 grounded plug (CEE7-7 for 230V) for easy "out of box" installation.

Warranty:

Classic Steamro Jr. hot dog steamer is covered by Star's one year parts and labor warranty.



**Model 35SSC
Operator Side**





CLASSIC STEAMRO, JR. HOT DOG STEAMER

Model 35SSC

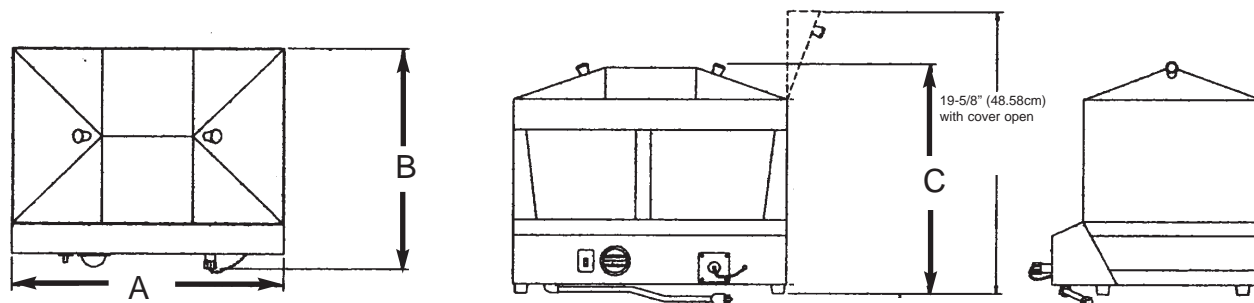

Capacity

Model No.	Hot Dogs Per Load (Standard Size)	Buns Per Load	Water Pan
35SSC	130	30-40	6 qts.

*Capacities will vary according to types and brands of hot dogs, bratwurst, etc.

Specifications

Model No.	Dimensions			Voltage	Wattage	NEMA Plug #	Approximate Weight	
	(A) Width Inches (cm)	(B) Depth Inches (cm)	(C) Height Inches (cm)				Installed (kg)	Shipping (kg)
35SSC	18 (45.7)	15 (38.1)	15-5/8 (39.7)	120V 230V	1000	5-15P CEE7-7	22 lbs. (55.9)	26-1/2 lbs. (67.3)

Accessories

Model #	Description
35T	Juice Tray

Typical Specifications

Model 35SSC side-by-side hot dog steamer is constructed of stainless steel with two individual removable stainless steel lids on both sides of unit for easy and safe access to hot dogs and buns. Unit has a six quart capacity stainless steel water pan and supplied with a convenient front drain valve. The unit is equipped with a 1000 watt tubular immersion type element, adjustable thermostat, on-off switch and 6ft. lead-in cord with grounded plug. Unit is UL, NSF and CE approved. Printed in the USA.